

Self Retaining Spacers Chamfered Stacking Self-Retaining Spacers

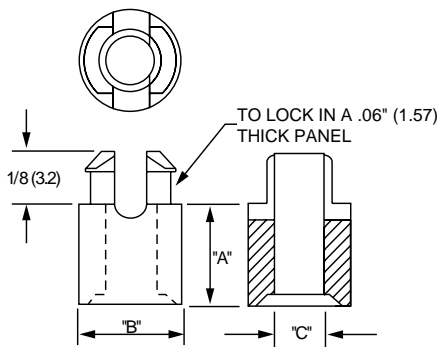

- Spacers are self-retaining and self-aligning
- Spacers stack to provide screw insulation in multi-level applications
- Board-mount head snaps in and maintains spacing even when screw is removed
- Design for use with #4, #6 and #8 screws. (M-3, M-3.5, M-4)
- Standard material molded from: U.L. rated 94V-2 nylon (natural) or flame retardant nylon rated 94V-0 (Off-White)



PART #						"A"		
For # 4 (M-3) Screw		For #6 (M-3.5) Screw		For # 8 (M-4) Screw				
94V-2 Nylon	94V-0 Nylon	94V-2 Nylon	94V-0 Nylon	94V-2 Nylon	94V-0 Nylon			
425-125	426-125					1/8"	(3.2)	
425-187	426-187					3/16"	(4.8)	
425-250	426-250	625-250	626-250	825-250	826-250	1/4"	(6.4)	
425-313	426-313	625-313	626-313	825-313	826-313	5/16"	(7.1)	
425-375	426-375	625-375	626-375	825-375	826-375	3/8"	(9.5)	
425-438	426-438	625-438	626-438	825-438	826-438	7/16"	(11.1)	
425-500	426-500	625-500	626-500	825-500	826-500	1/2"	(12.7)	
425-625	426-625	625-625	626-625	825-625	826-625	5/8"	(15.9)	
425-750	426-750	625-750	626-750	825-750	826-750	3/4"	(19)	
425-875	426-875	625-875	626-875	825-875	826-875	7/8"	(22.2)	
425-100	426-100	625-100	626-100	825-100	826-100	1"	(25.4)	
SCREW SIZE	94V-2 Nylon	94V-0 Nylon	"B"		"C"		Mounting Hole Dia. + .003 (.08)	
#4	425-	426-	.260"	(6.6)	.125"	(3.1)	.187"	(4.75)
#6	625-	626-	.312"	(7.1)	.153"	(3.9)	.234"	(5.94)
#8	825-	826-	.312"	(7.1)	.169"	(4.3)	.234"	(5.94)



Non-Chamfered Stacking Self-Retaining Spacer

- Board-mount head snaps in to maintain spacing even when screw is removed.
- Insulates head of screw from board
- Ideal for wood mounting
- Several sizes #4, #6 and #8 screws (M-3, M-3.5, M-4)
- Standard material molded from U.L. Rated 94V-2 nylon (natural) or flame retardant nylon rated 94V-0 (off-white)

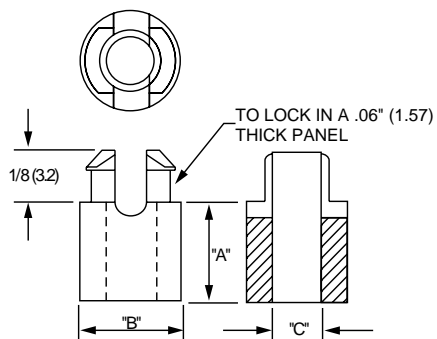

PART #						"A"		
For # 4 (M-3) Screw		For #6 (M-3.5) Screw		For # 8 (M-4) Screw				
94V-2 Nylon	94V-0 Nylon	94V-2 Nylon	94V-0 Nylon	94V-2 Nylon	94V-0 Nylon			
415-125	416-125					1/8"	(3.2)	
415-187	416-187					3/16"	(4.8)	
415-250	416-250	615-250	616-250	815-250	816-250	1/4"	(6.4)	
415-313	416-313	615-313	616-313	815-313	816-313	5/16"	(7.1)	
415-375	416-375	615-375	616-375	815-375	816-375	3/8"	(9.5)	
415-438	416-438	615-438	616-438	815-438	816-438	7/16"	(11.1)	
415-500	416-500	615-500	616-500	815-500	816-500	1/2"	(12.7)	
415-625	416-625	615-625	616-625	815-625	816-625	5/8"	(15.9)	
415-750	416-750	615-750	616-750	815-750	816-750	3/4"	(19)	
415-875	416-875	615-875	616-875	815-875	816-875	7/8"	(22.2)	
415-100	416-100	615-100	616-100	815-100	816-100	1"	(25.4)	
SCREW SIZE	94V-2 Nylon	94V-0 Nylon	"B"		"C"		Mounting Hole Dia. + .003 (.08)	
#4	415	416	.260"	(6.6)	.125"	(3.1)	.187"	(4.75)
#6	615	616	.312"	(7.1)	.153"	(3.9)	.234"	(5.94)
#8	815	816	.312"	(7.1)	.169"	(4.3)	.234"	(5.94)