

PANEL FASTENERS

RATCHET RIVETS

Two mating parts that securely connect flat panels. Ideal for both rigid and compressible material.

PART NUMBER	ASSEMBLED PANEL THICKNESS RANGE	HEAD DIAMETER AND THICKNESS
236-170406-00	.235-.297	.750/.093
236-170406-02	.346-.500	.750/.093
236-170406-03	.500-.812	.750/.093
236-170406-04	.780-1.375	.750/.093
236-170406-05	.235-.297	.406/.062
236-170406-07	.346-.500	.406/.062
236-170406-08	.500-.812	.406/.062
236-170406-09	.780-1.375	.406/.062

ASSEMBLY

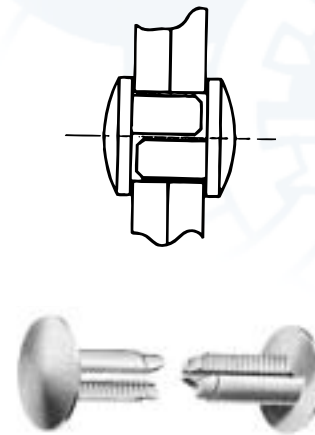

Assembly to fit a .281 diameter hole

Material: Nylon 66

NOTE: Dimensions listed are nominal.

SNAP RIVETS

Two mating parts that securely connect flat panels together. Ideal for both rigid and compressible materials.

ASSEMBLY		PANEL THICKNESS	HEAD DIAMETER AND THICKNESS OF MALE/FEMALE PART
MALE PART NO.	FEMALE PART NO.		
236-220603-00	236-220604-00	.170-.190	.625 DIA./062
236-220603-02	236-220604-00	.220-.240	.625 DIA./062
236-220603-05	236-220604-01	.170-.190	.460 DIA./062
236-220603-10	2700-00	.320-.340	.625 DIA./062

ASSEMBLY

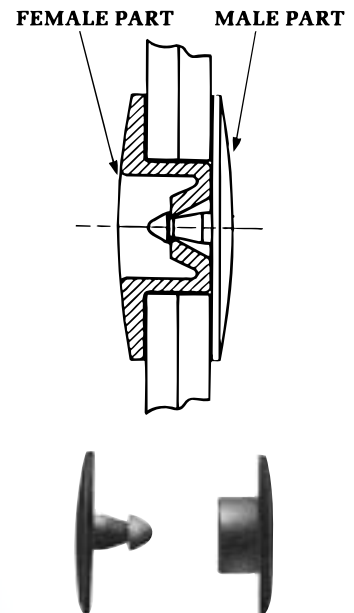

Assembly to fit a .320 diameter hole

Material: Nylon 66

Minimum Pull Out Force: 40 lbs, dry as molded

NOTE: Dimensions listed are nominal.