

FASTENERS

TREE-LOK FASTENER

Ball head fits neatly into plain bored hole or optional mating receptacle to securely lock access panels. Permits easy panel opening with moderate pressure.

| PART NUMBER | HOLE SIZE PANEL THICKNESS (PRONG) | RECEPTACLE PART NO. | HOLE SIZE PANEL THICKNESS |
|---|---|------------------------|-----------------------------------|
| 320-322880-00 STD. BALL | .437 DIA. | 320-221401-00 | .562 DIA. HOLE MIN. .468 PANEL |
| 320-322880-01 STANDOFF/ 1/4" BALL | .437 DIA. | 320-221401-00 | .562 DIA. HOLE MIN. .468 PANEL |
| 320-322880-03 MINI BALL | .312 DIA. | 320-221401-01 | .406 DIA. HOLE MIN. .137 PANEL |
| 320-322880-06 | .250 DIA. .040-.375 PANEL | 320-221401-00 | .562 DIA. HOLE MIN. .468 PANEL |

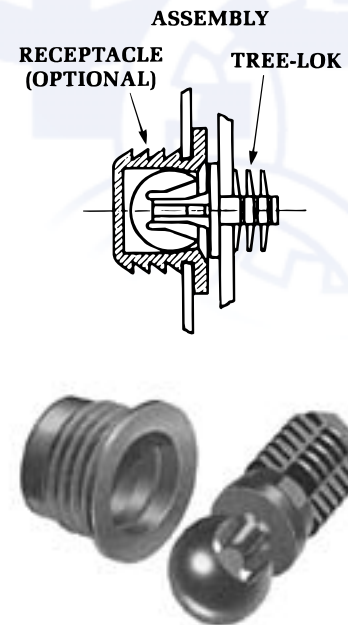

TREE-LOK can be used without receptacle. Mating panels hole size will change to .437 dia. or .312 dia.

Material: Nylon-66

NOTE: Dimensions listed are nominal.

STRIKE AND LATCH

Easily installed, rugged latching device for metal cabinet doors and access panels. Snaps in place through panel front.

| PART NUMBER | SPRING THICKNESS | HOLE SIZE (LATCH) PANEL RANGE | AVERAGE PUSH-IN PULL-OUT FORCES* |
|-------------|------------------|---|-------------------------------------|
| 7800-01** | .020 | .515 x .656 RECT. HOLE .035 TO .060 THK. PANEL | 10 LBS. |

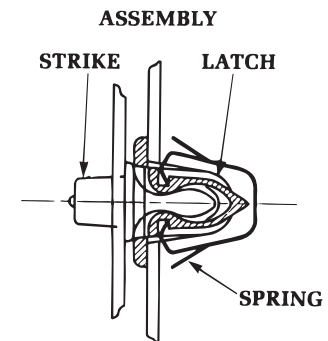

Strike: Part No. 263-000006-00, designed to fit a .286-.291 sq. hole in a .032-.052 thick panel.

Material: Latch – Nylon 66, Spring – Metal, Strike – Celcon

*These push-in, pull-out forces are given only as a guideline. User should evaluate for specific applications.

**Part Number Change from 7800-00

NOTE: Dimensions listed are nominal.

